

Cascading

Operating Manual to connect several control boxes SWT to each other

 For your own safety, read the complete product documentation before connecting the devices to form a cascaded network and putting it into operation.

1. REQUIRED COMPONENTS

- A. 2 to 4 motor columns
- B. Hand control
- C. 2 control boxes
- D. Power supply cables
- E. 1 cascading cable

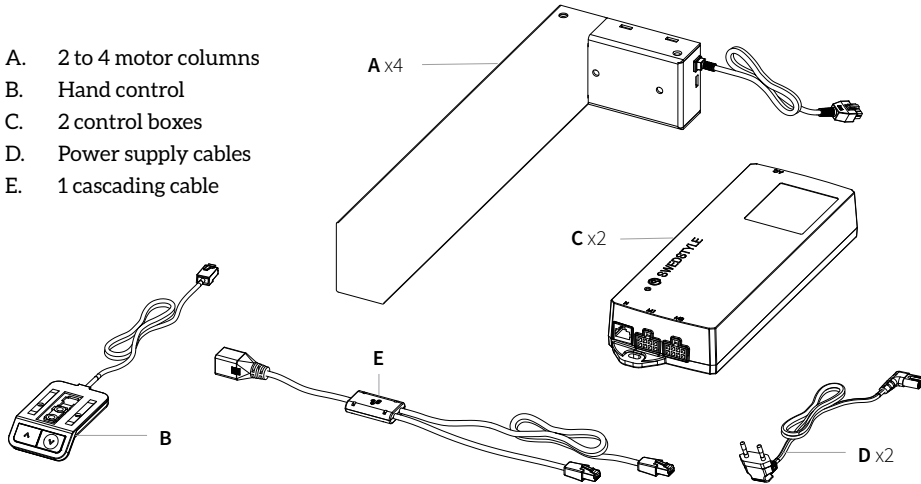

2. ACTIVATE CASCADED NETWORK WITH 2 CONTROL BOXES

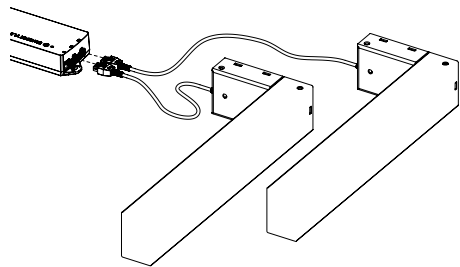

Before you start!

The control boxes has to be brand new boxes that has never been connected to a frame before.

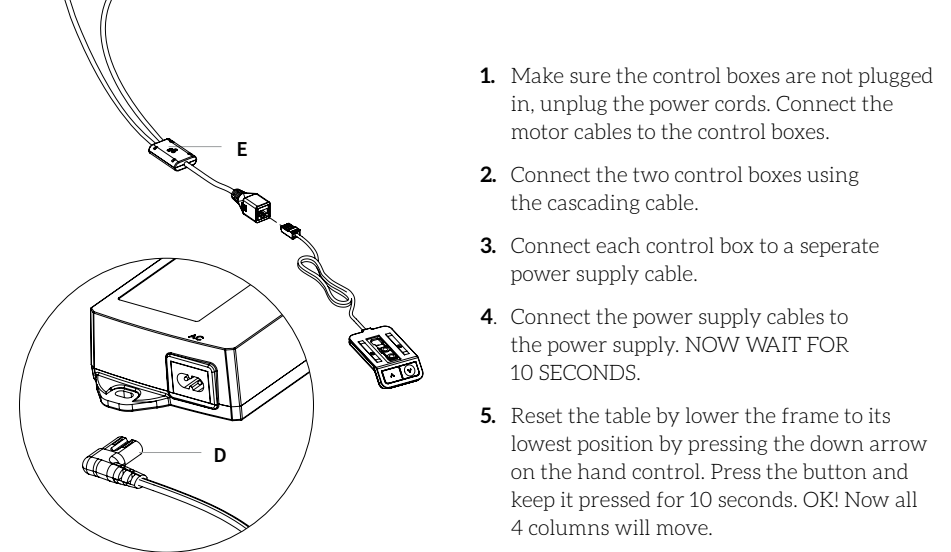
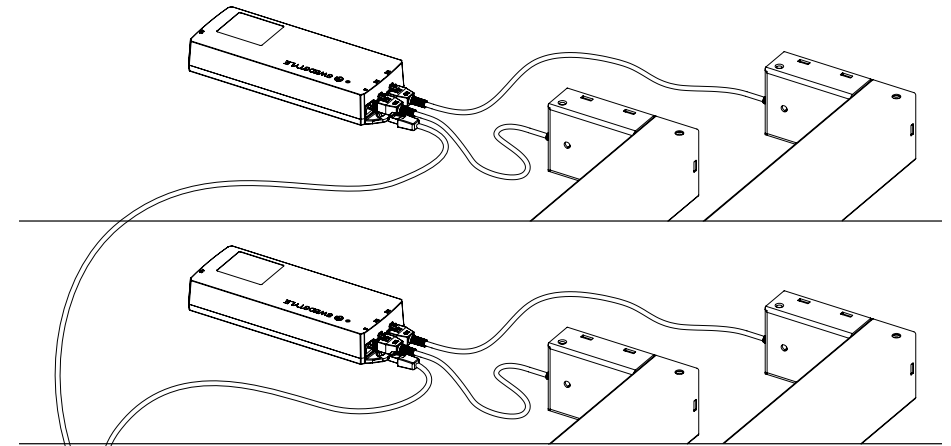

1. Make sure the control boxes are not plugged in, unplug the power cords. Connect the motor cables to the control boxes.
2. Connect the two control boxes using the cascading cable.
3. Connect each control box to a separate power supply cable.
4. Connect the power supply cables to the power supply. NOW WAIT FOR 10 SECONDS.
5. Reset the table by lower the frame to its lowest position by pressing the down arrow on the hand control. Press the button and keep it pressed for 10 seconds. OK! Now all 4 columns will move.

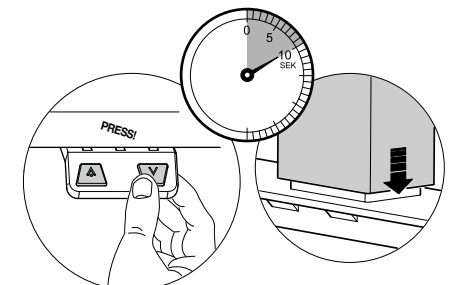
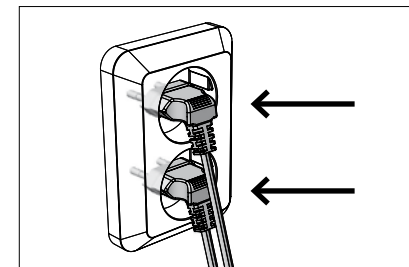



NOTICE Risk of damage to the system.

Ensure that all drives are moving in the same direction and are adjusting the height of the desktop during the reference drive. Misaligned drives may cause damage to the system.

3. REPLACING A CONTROL BOX IN A CASCADED NETWORK

To exchange control boxes in an existing cascading network, proceed as follows:

1. Disconnect the control boxes from the power supply.
2. Rebuild the cascaded network, see chapter 2.

4. REPLACING A MOTOR COLUMN IN A CASCADED NETWORK

To replace motor columns in an existing cascaded network, proceed as follows:

1. Disconnect the current motor column from the control box.
2. Connect the new motor column to the control box.
3. Perform a reset procedure, see chapter 2.5 on page 3.

Swedstyle AB.

Box 171, SE-567 24 Vaggeryd, Sweden

info@swedstyle.se

+46 393-363 60

www.swedstyle.com